

MAGNESENSE® II DIFFERENTIAL PRESSURE TRANSMITTER

Monitors Pressure, Air Velocity and Air Flow, BACnet or Modbus® Communications

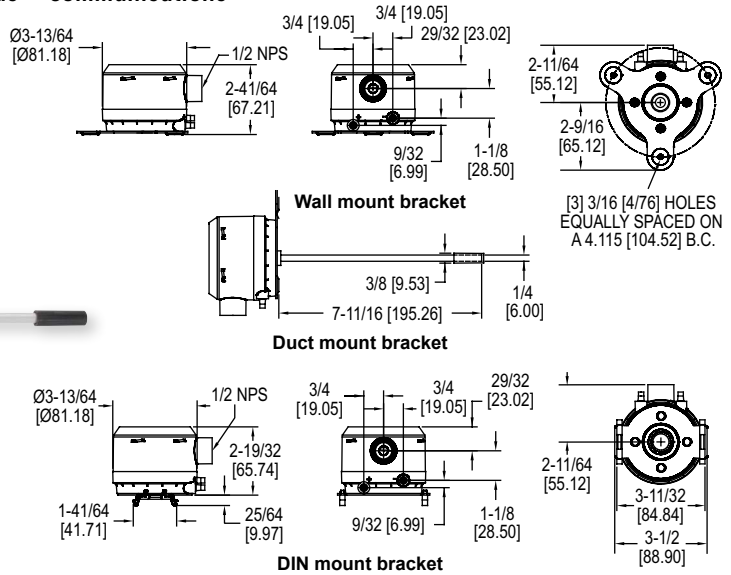

The **Series MS2 Magnesense® II Differential Pressure Transmitter** combines stable piezo sensing technology with additional features to reduce installation time and simplify ordering. Like the original Series MS, the second generation transmitter can be used as a linear pressure output or a linear velocity output with the square root extraction done in the transmitter. Additional parameters have been included on the MS2 to expand the square root capability to include flow measurements.

FEATURES/BENEFITS

- Field selectable ranges and output signal reduce inventory and the chances of ordering an incorrect part
- BACnet or Modbus® serial communications reduce wiring cost by daisy-chaining the transmitters
- Our integral field-upgradeable display or plug-in remote display tool save upfront material cost and allow for local viewing of measurements

APPLICATIONS

- Filter monitoring in air handler units
- Building pressure in pharmaceutical-semiconductor clean rooms
- Duct static pressure in commercial buildings
- Air velocity/flow in VAV systems

SPECIFICATIONS

Supported Baud Rates: 9600, 19200, 38400, 57600, 76800, 115200.
Data Size: 8.
Parity: None.
Stop Bits: 1.
Service: Air and non-combustible, compatible gases.
Wetted Materials: Consult factory.
Typical Accuracy: ±1% FS for 0.15 in w.c. (40 Pa), 0.25 in w.c. (50 Pa), 0.5 in w.c. (125 Pa), 2 in w.c. (500 Pa), 3 in w.c. (750 Pa), 5 in w.c. (1250 Pa), 10 in w.c. (2 kPa), 15 in w.c. (3 kPa), 25 in w.c. (5 kPa), 28 in w.c. (6.975 kPa); ±2% FS for 0.1 in w.c. (25 Pa), 1 in w.c. (250 Pa), and all bi-directional ranges.
Stability: ±1% / year FSO.
Temperature Limits: 0 to 150°F (-18 to 66°C).
Pressure Limits: 1 psi max., operation; 10 psi burst.
Power Requirements: 10-35 VDC (2-wire), 17-36 VDC or isolated 21.6-33 VAC (3-wire).
Output Signals: 4-20 mA (2-wire), 0-5 VDC, 0-10 VDC (3-wire).
Response Time: Averaging 0 to 240 s, 2.5 Hz sample rate, 1.5 to 228 s for 95% step change.
Zero & Span Adjustments: Digital push-buttons.
Loop Resistance: Current output: 0 to 1250 Ω max; Voltage output: Min. load resistance 1 kΩ.
Current Consumption: 40 mA max.
Display (Optional): 5 digit LCD.
Electrical Connections: 3-wire removable European style terminal block for 16 to 22 AWG.
Electrical Entry: 1/2" NPS thread; Accessory (A-151): Cable gland for 5 to 10 mm diameter cable.
Process Connection: 3/16" ID tubing (5 mm ID); Max. OD 9 mm.
Enclosure Rating: NEMA 4X (IP66).
Mounting Orientation: Any orientation.
Weight: 8.0 oz (230 g).
Agency Approvals: BTL, CE.

MODEL CHART

Model	in w.c.	Pa	mm w.c.	kPa
MS2-W101	0.10, 0.15, 0.25, 0.50	25, 40, 50, 125	2.5, 4, 6, 10	0.025, 0.04, 0.05, 0.125
MS2-W111	±0.10, ±0.15, ±0.25, ±0.50	±25, ±40, ±50, ±125	±2.5, ±4, ±6, ±10	±0.025, ±0.04, ±0.05, ±0.125
MS2-W102	1, 2, 3, 5	250, 500, 750, 1250	25, 50, 75, 125	0.25, 0.5, 0.75, 1.25
MS2-W112	±1, ±2, ±3, ±5	±250, ±500, ±750, ±1250	25, 50, 75, 125	0.25, 0.5, 0.75, 1.25
MS2-W103	10, 15, 25, 28	2500, 3500, 5000, 6975	250, 350, 500, 697.5	2.5, 3.5, 5.0, 6.975
	±10, ±15, ±25, ±28	±2500, ±3500, ±5000, ±6975	±250, ±350, ±500, ±697.5	±2.5, ±3.5, ±5.0, ±6.975

Note: For duct mount static probe change W to D. **Example:** MS2-D101
 For DIN rail mounting change W to N. **Example:** MS2-N101

OPTIONS

To order add suffix:	Description
-LCD	Units with display
Example: MS2-W101-LCD	
-BC	BACnet Communications
Example: MS2-W101-BC	
-MC	Modbus® Communications
Example: MS2-W101-MC	
-NIST	NIST traceable calibration certificate
Example: MS2-W101-NIST	
-FC	Factory calibration certificate
Example: MS2-W101-FC	

ACCESSORIES

Model	Description
A-151	Cable gland for 5 to 10 mm diameter cable
A-MS2-LCD	Field upgradeable display
A-435-A	Remote display tool
A-480	Plastic static pressure tip
A-481	Installer kit; includes 2 plastic static pressure tips and 7 ft (2.1 m) of PVC tubing
A-489	4" 303 SS straight static pressure tip with flange
A-302F-A	4" 303 SS static pressure tip with mounting flange; for 3/16" ID rubber or plastic tubing
SCD-PS	100-240 VAC/VDC to 24 VDC power supply

Modbus® is a registered trademark of Schneider Automation, Inc.
 Process Tubing Options: See page 455 (Gage Tubing Accessories)