

**Dwyer**

SERIES PFG2

# PROCESS FILTER GAGE

Indicates Process Filter Status, In-Line or Bottom Connect Mounting

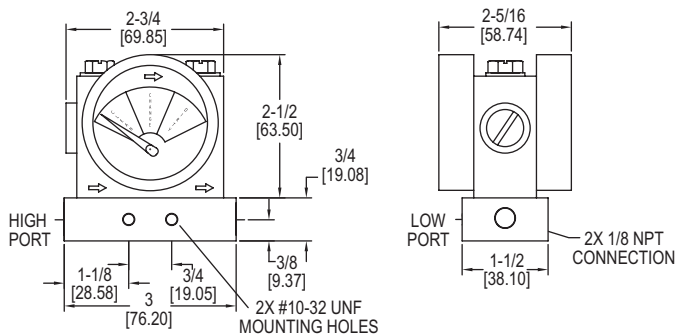

The **Series PFG2 Process Filter Gage** is designed for determining the state of an inline filter. The differential pressure indicator determines the pressure drop on either side of a filter and relates the value to one of three zones: clean (green), change (yellow), or dirty (red). The Series PFG2 is perfectly suited for filter applications, line loss, valve drop, and many other differential pressure applications where a simple indicator is needed. The direction of process flow is indicated on the dial, with the arrow pointing to the low pressure port. The PFG2 can be connected in-line through the side process connections, or can also be directly mounted through the outlet/inlet.

## FEATURES/BENEFITS

- Simple easy to understand indicator means no guessing filter status
- Removable mounting block provides direct mounting options especially in difficult filter access locations
- Quick installation reduces time to operation

## APPLICATIONS

- Filter pressure drop
- Filter status
- Valve drop
- Line loss

## SPECIFICATIONS

**Service:** Liquids/gases compatible with SS, GFN, and fluoropolymer.

**Wetted Materials:** Aluminum, SS, glass filled nylon, and fluoropolymer.

**Accuracy:**  $\pm 5\%$  FS.

**Temperature Limit:** 200°F (93°C).

**Pressure Limit:** 300 psig (20.7 bar).

**Materials:** Body: Glass filled nylon; Mounting Block: Aluminum; Lens: Polyester; Elastomers: Fluoroelastomer.

**Process Connection:** 1/8" female NPT.

**Mounting Orientation:** Any orientation with 10-32 threaded holes 3/4" apart.

**Weight:** 9.6 oz (272.2 g).

## MODEL CHART

Model	Full Range	Green Zone	Yellow Zone	Red Zone
PFG2-02	0 to 5 psid	0 to 2.5 psid	2.5 to 3.75 psid	3.75 to 5 psid
PFG2-03	0 to 10 psid	0 to 5 psid	5 to 7.5 psid	7.5 to 10 psid
PFG2-06	0 to 25 psid	0 to 11 psid	11 to 18.5 psid	18.5 to 25 psid