

July 2025

Description

The versatile SIX can be used as a signal isolator, converter, and repeater. Ideal for installation in the plant and control room, the 2-wire (loop-powered) SIX derives its power from the process loop, eliminating the need to install an additional power supply.

Isolator—The SIX provides total isolation between the signal from a non-isolated transmitter and a receiving device. This eliminates faulty readings in process measurement and control equipment caused by ground loops, motor noise, and other electrical interference.

Converter—Acting as a precise interface, the SIX allows transmitters, transducers, controllers, recorders, and control systems with dissimilar signals to communicate with one another.

Repeater/Diverter—The SIX can be used to increase drive capability to a process loop, allowing installation of additional instruments on the loop. The SIX also is excellent for “diverting” a secondary signal from a process loop to a recorder, indicator, or other similar device.

Solves “Bucking Power Supplies”

Many plants encounter problems when trying to interface a DCS with a 4-wire (line-powered) transmitter. Both units are supplying power to the same loop, which results in “Bucking Power Supplies” and a non-functioning loop. If neither power supply can be eliminated, install a SIX between the two. It operates with powered inputs from both sides, thus restoring normal operations to the loop.

Figure 1. The SIX provides isolation between a non-isolated transmitter and a receiving device.

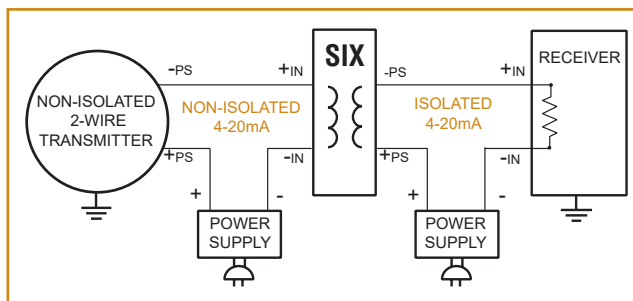

The SIX's DIN-style housing mounts quickly and easily on G-type and Top Hat rails. Removable terminal blocks speed installation and maintenance.

Features

- **Stops ground loops.** Complete isolation stops ground loops from affecting the integrity of a transmitted process signal.
- **Wide range of inputs and outputs.** Available models offer input and output combinations to handle common and unusual applications.
- **Low current impedance/high drive capability.** The SIX's exceptionally low 50 ohms (for 4-20mA input) impedance doesn't load existing loops and regenerates signals.
- **RFI/EMI protection.** Inherent 10V/m immunity protects the SIX in most applications. For especially noisy environments, choose the -RF option which provides superior 20V/m protection.

Certifications



Underwriter's Laboratories: Ordinary (non-hazardous) or Hazardous Locations* Class I, Division 2, Groups A, B, C & D T4



CE Conformant EMC Directive 2014/30/EU – EN 61326

SIX

2-Wire Signal
Isolator/Converter

Specifications

Performance

Accuracy: ±0.1% of span
Linearity: ±0.1% of span
Isolation: WITHOUT -RF OPTION:
 1500Vrms between input and output; WITH
 -RF OPTION: 500Vrms between input and
 output
Maximum Input Overrange: Current Inputs
 250% of full scale; DC Voltage Inputs, 150%
 of full scale
Input Impedance: 50 ohms for 4-20mA
 and 0-20mA inputs; 1.0Mohms for voltage
 inputs 10V and below; see Input section for
 additional ranges
 Add 20 ohms for 50mA input
Frequency Response: -3dB at 10Hz

Performance (continued)

Load Capability: $\frac{V_s - 12V}{0.02A} = \text{ohms}$

Output Current Limiting: 25mA typical;
 30mA maximum

Power Supply Effect: <0.05% of span
 over the full power supply range

RFI/EMI Protection: Less than ±0.1% of
 span error when tested at 10V/m@ 20-
 1000MHz; WITH -RF OPTION: Less than
 ±0.1% of span error when tested at 20V/m
 @80-1000MHz, 1kHz AM

Output Tracking: Assuming 4-20mA input
 and 4-20mA output, the isolator output will
 follow the input below 3mA when the input
 fails.

Ambient Temperature

Operating Range: -40°C to +85°C
 (-40°F to +185°F)

Storage Range: -40°C to +85°C
 (-40°F to +185°F)

Ambient Temperature Effect: ±0.007%
 of span/°C typical; ±0.015% of span/°C
 maximum; Ambient Temperature Reference
 Conditions for Specifications: 25°C

Adjustments

Type: External multiturn potentiometers

Span: ±10% of span

Zero: ±5% of span

Weight

190g (6.7 oz)

Ordering Specifications

Unit	Input	Output	Power	Options	Housing	
SIX	-1MATO+1MA 0-1MA 0-20MA 4-12MA 12-20MA 4-20MA 10-50MA 0-50MV 0-100MV 0-200MV 0-500MV	-10VTO+10V 0-1V 0-2V 0-5V 0-10V 0-30V 0-50V 0-100V 0.2-1V 1-5V	4-20MA into 600 ohms with 24Vdc power supply 10-50MA into 600 ohms with 42Vdc power supply	12-42DC (loop- powered on output side)	-BI Bailey input (must be specified with -10V To +10V input type) -RF Enhanced RFI/EMI filtering provides 20V/m@ 20-1000MHz, 1kHz AM protection with less than ±0.1% of span error -VTD Standard Factory Calibration with NIST Test Data Report	DIN DIN-style housing mounts on 32mm G-type (EN50035) and 35mm Top Hat (EN50022) rails FLB2 Externally- mounted flange provides a secure mount and ensures resistance to vibration

To order, specify: Unit / Input / Output / Power / Options [Housing]

Model Number Examples: SIX / 4-20MA / 4-20MA / 12-42DC / -RF [DIN]

Figure 2. Installation Dimensions and Terminal Designations.

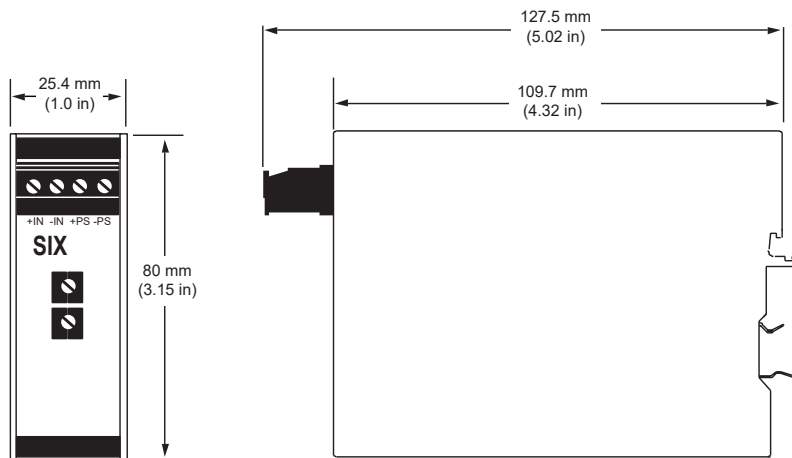

United States • info@miinet.com
 Tel: (818) 894-7111 • FAX: (818) 891-2816
 Australia • sales@mooreind.com.au
 Tel: (02) 8536-7200 • FAX: (02) 9525-7296

Demand Moore Reliability

www.miinet.com

BeNeLux • info@mooreind.eu
 Tel: 03/448.10.18 • FAX: 03/440.17.97

China • sales@mooreind.sh.cn
 Tel: 86-21-62491499 • FAX: 86-21-62490635
 United Kingdom • sales@mooreind.com
 Tel: 01293 514488 • FAX: 01293 387752