



Signal Isolator/Converter

# SIX

## User's Manual

All product names are registered trademarks of their respective companies.

## Customer Support

Moore Industries is recognized as the industry leader in delivering top quality to its customers in products and services. We perform a sequence of stringent quality assurance checks on every unit we ship. If any Moore Industries product fails to perform up to rated specifications, call us for help. Our highly skilled staff of trained technicians and engineers pride themselves on their ability to provide timely, accurate, and practical answers to your process instrumentation questions. Our headquarters and other facilities phone numbers are listed below.

There are several pieces of information that can be gathered before you call the factory that will help our staff get the answers you need in the shortest time possible. For fastest service, gather the complete model and serial number(s) of the problem unit(s) and the job number of the original sale.

## Locations

### World Headquarters

16650 Schoenborn Street North  
Hills, California  
91343-6196, **U.S.A.**  
Tel: (818) 894-7111  
Fax: (818) 891-2816  
E-mail: [info@miinet.com](mailto:info@miinet.com)  
TOLL FREE: 1-800-999-2900  
**[www.miinet.com](http://www.miinet.com)**

### Europe

1 Lloyds Court, Manor Royal,  
Crawley  
W. Sussex RH10-9QU  
**United Kingdom**  
Tel: 01293 514488  
Fax: 01293 387752  
FREE PHONE: 0800 525107  
[sales@mooreind.com](mailto:sales@mooreind.com)

### Australia

Sydney, NSW  
3/1 Resolution Drive  
Caringbah, New South Wales 2229  
**Australia**  
Tel: (02) 8536-7200  
Fax: (02) 9525-7296  
[sales@mooreind.com.au](mailto:sales@mooreind.com.au)

### China

Room 902, Building 8, West Zone,  
Zhaoshang HongQiao Gongguan,  
Phase II, Lane 299,  
Shanghan Road, Xujing Town,  
Qingpu District, Shanghai, China  
Postal Code 201702  
Tel: 86-21 62491499  
Fax: 86-21 62490635  
E-mail: [sales@mooreind.sh.cn](mailto:sales@mooreind.sh.cn)  
[www.miinet.com](http://www.miinet.com)

### **BeNeLux**

Guido Gezellestraat 106  
BE-2630 Aartselaar  
**Belgium**  
Tel: 03/448.10.18  
Fax: 03/440.17.97  
[info@mooreind.eu](mailto:info@mooreind.eu)

Perth, WA  
6/46 Angove Street  
North Perth, Western Australia 6006  
**Australia**  
Tel: (08) 9228-4435  
Fax: (08) 9228-4436  
[sales@mooreind.com.au](mailto:sales@mooreind.com.au)



[www.miinet.com](http://www.miinet.com)

## Table of Contents

<b>Introduction</b>	<b>4</b>
<b>Description</b>	<b>4</b>
<b>Calibration</b>	<b>4</b>
<b>Installation</b>	<b>8</b>
<b>Operation</b>	<b>10</b>
<b>Maintenance</b>	<b>10</b>
<b>Troubleshooting</b>	<b>10</b>

## Introduction

Moore Industries' Signal Isolator/Converter (SIX) is a DIN-style, loop-powered device, used to provide complete isolation of instrumentation input and output. This helps eliminate faulty readings in measurement and control equipment caused by ground loops, electrical interference, or motor noise.

This manual provides a brief description of the SIX, a list of performance and functional specifications, a calibration procedure, operations notes, and troubleshooting information.

Notes and Cautions, where they appear in text or illustrations, are provided to assist the user in avoiding operational inconveniences (Notes), or practices that otherwise might result in damage to the unit (Cautions).

## Description

The SIX is loop-powered. When connected in a 12-42 Vdc loop, it converts a standard process current or voltage signal to a proportional, isolated 4-20 or 10-50 mA output; breaking the galvanic path between a transmitted signal source and its receiving device.

The unit is packaged in a compact, DIN-style housing that snaps easily on to G-rail mounting hardware (DIN EN50035). This makes it ideal for use in high density installations.

## Controls

The SIX has Zero and Span potentiometers located on the front panel of the unit. On older units these were labeled:

→0← for Zero, and

|←→| for Span.

On newer the words "ZERO" and "SPAN" may be used to identify the potentiometers.

Table 1 consists of the SIX performance and functional specifications.

## Options

Units may be ordered with RFI-filtered terminals and case assembly (RF Option). RF-equipped units provides less than  $\pm 0.1\%$  of span error when tested at 10V/m@ 20-1000MHz.

Contact your Sales Representative or Moore Industries for more information on available SIX options and compatible devices.

**Serial Number.** A complete history of every unit sold and serviced by Moore Industries is kept at the factory. This data is keyed to each unit's serial number. If service data is required on an SIX, providing the factory with the unit serial number will allow our highly skilled technicians to better assist you.

The SIX serial number is located on a label affixed to the side panel of the unit.

**Model Number.** Moore Industries' model numbers identify the type of instrument, functional characteristics, operating parameters, any options ordered, and housing type. If all accompanying documentation for a unit is missing, the model number may be used to obtain technical information.

The model number for the SIX is located on the same label as its serial number.

The example following Table 1 is provided to assist in deciphering the fields of the SIX model number.

## Calibration

Prior to unit shipment, each SIX is calibrated and tested according to Moore Industries' strict quality control guidelines. It is recommended, however, that a bench check of potentiometer settings and output levels be performed before placing the SIX into service.

# SIX

2-Wire Signal  
Isolator/Converter

## Specifications

<p><b>Performance</b></p> <p><b>Accuracy:</b> ±0.1% of span  <b>Linearity:</b> ±0.1% of span  <b>Isolation:</b> WITHOUT -RF OPTION: 1500Vrms between input and output; WITH -RF OPTION: 500Vrms between input and output  <b>Maximum Input Overrange:</b> Current Inputs 250% of full scale; DC Voltage Inputs, 150% of full scale  <b>Input Impedance:</b> 50 ohms for 4-20mA and 0-20mA inputs; 1.0Mohms for voltage inputs 10V and below; see Input section for additional ranges  Add 20 ohms for 50mA input  <b>Frequency Response:</b> -3dB at 10Hz</p>	<p><b>Performance (continued)</b></p> <p><b>Load Capability:</b> <math>\frac{V_s - 12V}{0.02A} = \text{ohms}</math></p> <p><b>Output Current Limiting:</b> 25mA typical; 30mA maximum  <b>Power Supply Effect:</b> &lt;0.05% of span over the full power supply range  <b>RFI/EMI Protection:</b> Less than ±0.1% of span error when tested at 10V/m@ 20-1000MHz; WITH -RF OPTION: Less than ±0.1% of span error when tested at 20V/m @80-1000MHz, 1kHz AM  <b>Output Tracking:</b> Assuming 4-20mA input and 4-20mA output, the isolator output will follow the input below 3mA when the input fails.</p>	<p><b>Ambient Temperature</b>  <b>Operating Range:</b> -40°C to +85°C (-40°F to +185°F)  <b>Storage Range:</b> -40°C to +85°C (-40°F to +185°F)  <b>Ambient Temperature Effect:</b> ±0.007% of span/°C typical; ±0.015% of span/°C maximum; Ambient Temperature Reference Conditions for Specifications: 25°C</p> <p><b>Adjustments</b>  <b>Type:</b> External multturn potentiometers  <b>Span:</b> ±10% of span  <b>Zero:</b> ±5% of span</p> <p><b>Weight</b>  190g (6.7 oz)</p>
---------------------------------------------------------------------------------------------------------------------------------------------------------------------------------------------------------------------------------------------------------------------------------------------------------------------------------------------------------------------------------------------------------------------------------------------------------------------------------------------------------------------------------------------------------------------------------------	------------------------------------------------------------------------------------------------------------------------------------------------------------------------------------------------------------------------------------------------------------------------------------------------------------------------------------------------------------------------------------------------------------------------------------------------------------------------------------------------------------------------------------------------------------------------------------------------------------------------	-----------------------------------------------------------------------------------------------------------------------------------------------------------------------------------------------------------------------------------------------------------------------------------------------------------------------------------------------------------------------------------------------------------------------------------------------------------------------------------------------------------------

## Ordering Specifications

Unit	Input	Output	Power	Options	Housing
SIX	<b>0-20MA</b> into 50 ohms <b>4-20MA</b> into 50 ohms <b>10-50MA</b> into 70 ohms <b>0-1MA</b> into 1kohms <b>-1TO+1mA</b> into 1kohms <b>.2-1V</b> into 1Mohms <b>0-1V</b> into 1Mohms <b>0-5V</b> into 1Mohms <b>1-5V</b> into 1Mohms <b>0-10V</b> into 1Mohms <b>-10VTO+10V</b> into 1Mohms <b>0-30V</b> into 1Mohms	<b>4-20MA</b> into 600 ohms with 24Vdc power supply <b>10-50MA</b> into 600 ohms with 42Vdc power supply	<b>12-42DC</b> (loop-powered on output side)	<b>-BI</b> Bailey input (must be specified with -10V To +10V input type) <b>-RF</b> Enhanced RFI/EMI filtering provides 20V/m@ 20-1000MHz, 1kHz AM protection with less than ±0.1% of span error <b>-VTD</b> Standard Factory Calibration with NIST Test Data Report	<b>DIN</b> DIN-style housing mounts on 32mm G-type (EN50035) and 35mm Top Hat (EN50022) rails <b>FLB2</b> Externally-mounted flange provides a secure mount and ensures resistance to vibration

To order, specify: Unit / Input / Output / Power / Options [Housing]

Model Number Examples: SIX / 4-20MA / 4-20MA / 12-42DC / -RF [DIN]

### Certifications



**Underwriter's Laboratories:** Ordinary (non-hazardous) or Hazardous Locations\* Class I, Division 2, Groups A, B, C & D T4

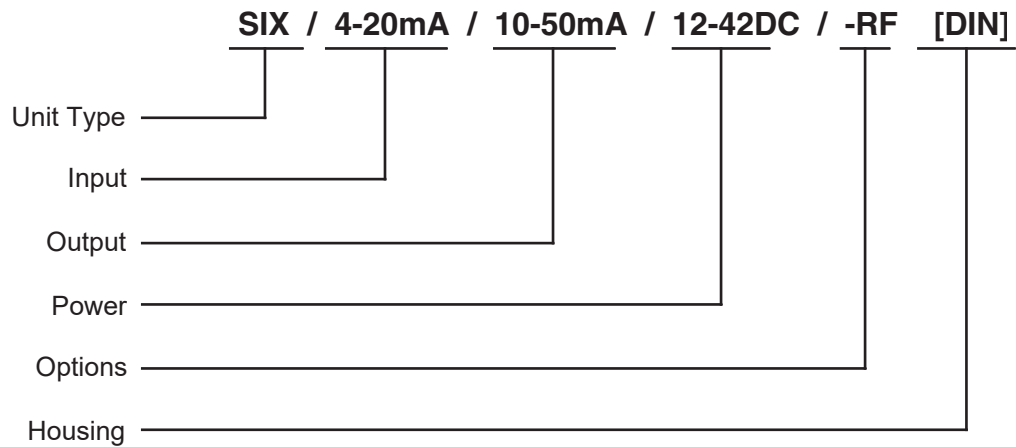

**CE Conformant** EMC Directive 2014/30/EU – EN 61326

**EXAMPLE****Table 2.** SIX Calibration Equipment

<b>Equipment</b>	<b>Characteristics</b>
<b>Signal Source</b>	Appropriate for the intended SIX application, accurate to within $\pm 0.05\%$ of span, minimum
<b>DC milliammeter</b> or <b>DC voltmeter with Precision resistor</b>	Fluke model 8899, or equivalent unit accurate to within $\pm 0.05\%$ of span, minimum.  Voltmeter accurate to within $\pm 0.05\%$ of span, minimum. Resistor: 250ohm ( $\pm 0.1\%$ ), rated for 4-20 mA.
<b>Power Supply</b>	Capable of 12 to 42 Vdc.
<b>Screwdriver</b>	Slotted head, width 2.54 mm (0.1 inch).

**Calibration Equipment**

Table 2 lists the calibration equipment required for this bench check procedure. This equipment is not supplied with the unit.

# SIX

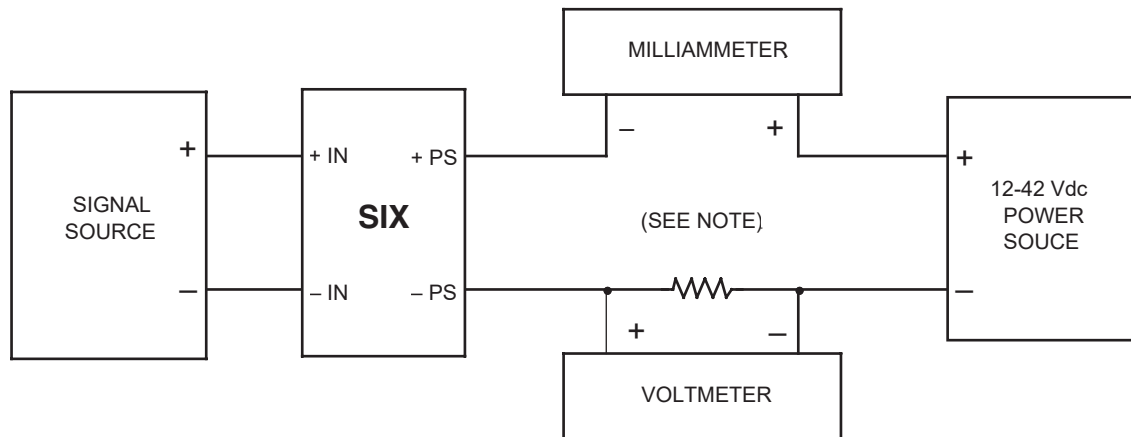

**NOTE:** Either milliammeter or voltmeter may be used for monitoring output.

**Figure 1.** SIX Calibration Setup

## Calibration Setup

Figure 1 shows the calibration setup for the SIX. To check or calibrate the SIX, connect the unit as shown in the illustration, and apply the power according specification (refer to the specifications table and the model number of your unit).

Note that there are no internal adjustments or settings to effect on the SIX. Disassembly of any kind is not recommended.

After applying power, allow approximately five minutes for stabilization/warm-up.

## Calibration Procedures

There are two options for monitoring the output of the SIX shown in the figures; either a dc milliammeter or a dc voltmeter with load resistor may be used to monitor and set output levels.

1. With the calibration setup complete, adjust both potentiometers 15 turns counterclockwise, then 7.5 turns clockwise (mid-scale).
2. Simulate zero percent input.

3. Adjust zero potentiometer until milliammeter reads 4 mA for 4-20 mA units, 10 mA for 10-50 mA units, or until voltmeter reads 1 volt.

### **CAUTION**

*To avoid damaging the housings, use a screwdriver with a head not wider than 2.54 mm (0.1 inch) to adjust the zero and span potentiometers.*

4. Set input to 100 percent.
5. Adjust span potentiometer until milliammeter reads 20 mA for 4-20 mA units, 50 mA for 10-50 mA units, or until voltmeter reads 5 volts.
6. Repeat steps 2 through 5 until zero and 100 percent readings are stable,  $\pm 0.1\%$ .

## Installation

In this manual, the installation of the SIX is divided into two phases: physically mounting the unit, and making the electrical connections. It is recommended that the unit(s) be mounted before making any connections.

## Mounting

When mounting the SIX, make every effort to install it in an area that is relatively free of dust, moisture, and corrosive materials.

Figure 2 shows the mounting dimensions for the SIX.

To mount the unit on a DIN-style G-rail, insert the metal clip on the unit's back panel under the top lip of the rail. Pivoting on the clip, press down firmly until the SIX snaps into place.

If it becomes necessary to remove the unit, grasp the bottom of its front panel and lift upward.

### **NOTE**

*The SIX has no case ground connection. If possible, avoid mounting the unit in any electrical field. Secure the case to a good conductor at zero potential.*

Figure 2. Installation Dimensions and Terminal Designations.

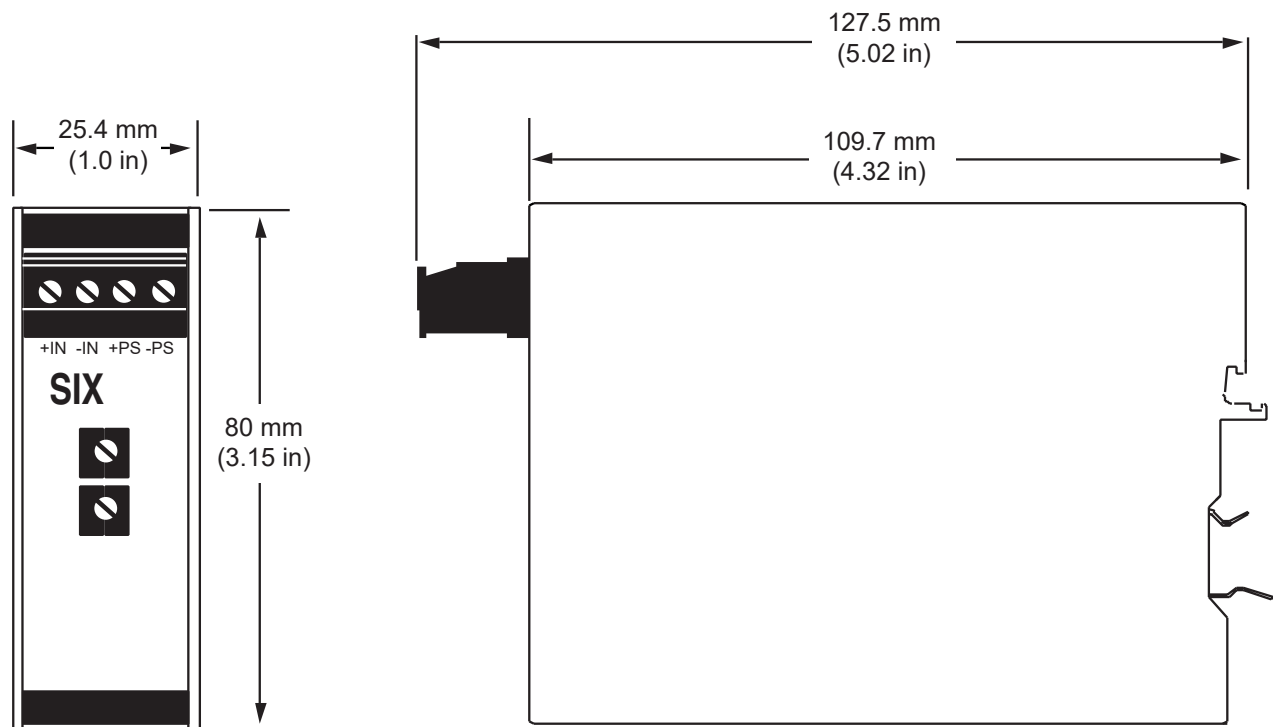

# SIX

## Electrical Connections

The SIX has four terminals on its front panel. They are labeled “+IN” and “-IN” for connection of the signal input, and “+PS” and “-PS” for connection of the unit’s output.

Figure 3 illustrates the connection of the SIX in a generic application.

Figure 4 shows the unit connected in another typical operational scenario.

To complete these connections, use a small, slotted screwdriver to loosen the SIX terminal screws, and slip the appropriate stripped wire end into the terminal hole. Tighten the terminal screw.

Both the input and output may be grounded. The SIX input and output are isolated with no dc connection between them.

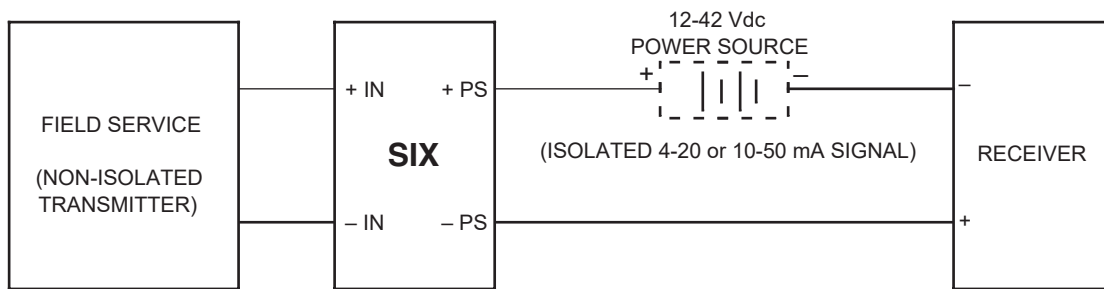

**Figure 3.** *SIX Typical Installation Hookup*

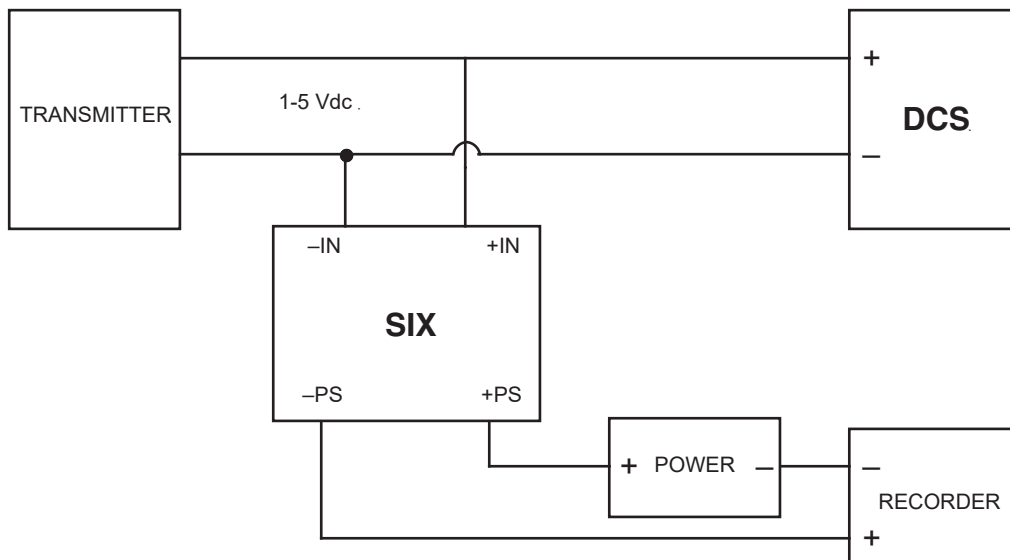

**Figure 4.** *SIX Installed as a Repeater/Diverter*

## Installation in Hazardous Locations

This section contains important information regarding installation of the SIX in Hazardous Area locations.

**NOTE:** The SIX is suitable for Class I Division 2, Groups A-D or General Locations only.

**WARNING:** Do not disconnect equipment when a flammable or combustible atmosphere is present.

**AVERTISSEMENT:** Risque d'explosion. Ne pas débrancher tant que le circuit est sous tension, à moins qu'il ne s'agisse d'un emplacement non dangereux.

**AVERTISSEMENT:** Risque d'explosion. La substitution de composants peut rendre ce matériel inacceptable pour les emplacements de Classe I, Division 2.

## Specific Conditions of Use

The following instructions must be adhered to when the SIX is used in hazardous locations and potentially explosive atmospheres.

The SIX shall be installed in compliance with the enclosure, mounting, spacing and segregation requirements of the ultimate application.

cULus Installation  
Nonincendive Applications  
Class I, Division 2, Groups A-D\*

\*Certification not applicable to models equipped with the -RF option.

The SIX shall be installed into an enclosure that utilizes a tool removable door or cover.

## Customer Support

Moore Industries is recognized as the industry leader in delivering top quality to its customers, both in products and services. We perform a battery of stringent quality assurance checks on every unit we ship. If any Moore Industries product fails to perform up to rated specification, call us for help. Our highly skilled staff of trained technicians and engineers pride themselves on their ability to provide timely, accurate, and practical answers to your process instrumentation questions.

If problems involve a particular SIX, there are several pieces of information you can gather before you call the factory that will help our staff get your answers more efficiently. When you call, please have:

- The model number of the unit in question
- The serial number of the unit in question
- The job number (if available)
- The purchase order under which the unit was shipped (if available)

Contact information can be found in the front of this manual.

## Operation

Once mounted and connected according to the instructions, the SIX operates unattended. After the initial calibration of the Zero and Span potentiometers, no further adjustment is required.

## Maintenance

A check of terminal connections is recommended every six months. Ensure that all terminal screws are tight and free of corrosion. Check that adequate ventilation exists, or that heat sinking materials are used in mounting.

## Troubleshooting

If the SIX is found to be performing below specification, complete the following checklist:

1. Make sure all connections are clean and tight.
2. Verify the accuracy and calibration of bench instruments used to take measurements.
3. Ensure that signal and power levels in the instrumentation loop have not changed since the unit was installed. Make sure that power is within specified limits (refer to table 1).

If problems persist, note the serial and model numbers of the offending unit, and contact Moore Industries' Customer Service Department. Instructions for return of Moore Industries equipment are on the back cover of this manual.

## Warranty Disclaimer

Moore Industries ("The Company") makes no express, implied or statutory warranties (including any warranty of merchantability or of fitness for a particular purpose) with respect to any goods or services sold by the company. The company disclaims all warranties arising from any course of dealing or trade usage, and any buyer of goods or services from the company acknowledges that there are no warranties implied by custom or usage in the trade of the buyer and of the company, and that any prior dealings of the buyer with the company do not imply that the company warrants the goods or services in any way.

Any buyer of goods or services from the company agrees with the company that the sole and exclusive remedies for breach of any warranty concerning the goods or services shall be for the company, at its option, to repair or replace the goods or services or refund the purchase price. The company shall in no event be liable for any consequential or incidental damages even if the company fails in any attempt to remedy defects in the goods or services, but in such case the buyer shall be entitled to no more than a refund of all monies paid to the company by the buyer for purchase of the goods or services.

Any cause of action for breach of any warranty by the company shall be barred unless the company receives from the buyer a written notice of the alleged defect or breach within ten days from the earliest date on which the buyer could reasonably have discovered the alleged defect or breach, and no action for the breach of any warranty shall be commenced by the buyer any later than twelve months from the earliest date on which the buyer could reasonably have discovered the alleged defect or breach.

## Return Policy

For a period of thirty-six (36) months from the date of shipment, and under normal conditions of use and service, Moore Industries ("The Company") will at its option replace, repair or refund the purchase price for any of its manufactured products found, upon return to the Company (transportation charges prepaid and otherwise in accordance with the return procedures established by The Company), to be defective in material or workmanship. This policy extends to the original Buyer only and not to Buyer's customers or the users of Buyer's products, unless Buyer is an engineering contractor in which case the policy shall extend to Buyer's immediate customer only. This policy shall not apply if the product has been subject to alteration, misuse, accident, neglect or improper application, installation, or operation. THE COMPANY SHALL IN NO EVENT BE LIABLE FOR ANY INCIDENTAL OR CONSEQUENTIAL DAMAGES.

## To return equipment to Moore Industries for repair, follow these four steps:

1. Call Moore Industries and request a Returned Material Authorization (RMA) number.

### Warranty Repair –

If you are unsure if your unit is still under warranty, we can use the unit's serial number to verify the warranty status for you over the phone. Be sure to include the RMA number on all documentation.

### Non-Warranty Repair –

If your unit is out of warranty, be prepared to give us a Purchase Order number when you call. In most cases, we will be able to quote you the repair costs at that time. The repair price you are quoted will be a "Not To Exceed" price, which means that the actual repair costs may be less than the quote. Be sure to include the RMA number on all documentation.

2. Provide us with the following documentation:
  - a) A note listing the symptoms that indicate the unit needs repair
  - b) Complete shipping information for return of the equipment after repair
  - c) The name and phone number of the person to contact if questions arise at the factory
3. Use sufficient packing material and carefully pack the equipment in a sturdy shipping container.
4. Ship the equipment to the Moore Industries location nearest you.

The returned equipment will be inspected and tested at the factory. A Moore Industries representative will contact the person designated on your documentation if more information is needed. The repaired equipment, or its replacement, will be returned to you in accordance with the shipping instructions furnished in your documentation.



**Demand Moore Reliability • [www.miinet.com](http://www.miinet.com)**

United States • <a href="mailto:info@miinet.com">info@miinet.com</a>	China • <a href="mailto:sales@mooreind.sh.cn">sales@mooreind.sh.cn</a>
Tel: (818) 894-7111 • FAX: (818) 891-2816	Tel: 86-21-62491499 • FAX: 86-21-62490635
Australia • <a href="mailto:sales@mooreind.com.au">sales@mooreind.com.au</a>	BeNeLux • <a href="mailto:info@mooreind.eu">info@mooreind.eu</a>
Tel: (02) 8536-7200 • FAX: (02) 9525-7296	United Kingdom • <a href="mailto:sales@mooreind.com">sales@mooreind.com</a>
	Tel: 01293 514488 • FAX: 01293 387752